

DALSTAR CA-D1



This progressive scan camera uses a Frame

Transfer architecture

it has an on-chip shielded storage region.

High frame rates, large pixels, and an easy-to-interface single output make this progressive scan area camera adaptable to a wide range of applications.

Output options such as pixel binning and available 12-bit digitization (CA-D1-xxxxT models) make this progressive scan area camera adaptable to a wide range of applications. DALSA's patented modular architecture provides a high-performance camera with the reliability, flexibility, and cost-effectiveness of high-volume interchangeable parts.

Features

- 7 Progressive scan readout
- 7 On-chip shutter
- 7 Binning
- 7 Multi-camera synchronization
- 7 100% fill factor

Specifications

Resolution	128 x 128 / 256 x 256
Pixel Size	16µm x 16µm
Aperture	2.1x2.1 / 4.1x4.1mm
Lens Mount	C-mount
Max. Line/Frame Rate	736 / 203fps or 490 / 136fps
Data Rate	15 or 10MHz
Data Format	8-bit or 12-bit RS422
Responsivity	4.2DN or 80DN/(nJ/cm ²) broadband
Dynamic Range	496:1 or 1320:1
Nominal Gain Range	fixed
Size	89x89x83mm
Mass	0.8kg
Operating Temp	0-40 C
Power Supply	+5V, -5V, +15V, -15V
Power Dissipation	<10W
Regulatory Compliance	



Applications

- 7 Motion tracking
- 7 Instrumentation

Sensor

The CA-D1 uses DALSA's IA-D1 frame transfer image sensor. See the IA-D1 datasheet for more details.

Connectors

Control	DB25M
Data	2xIDC 20-pin
Power	shared with control

Other BNC for analog reference

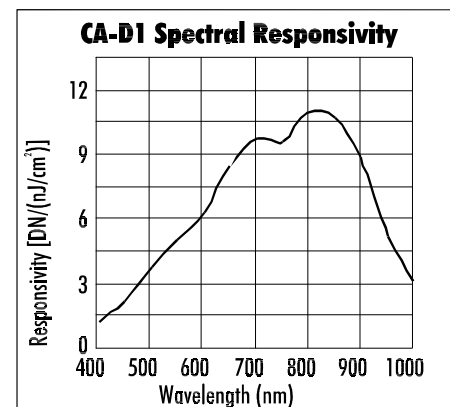

Mechanical Dimensions

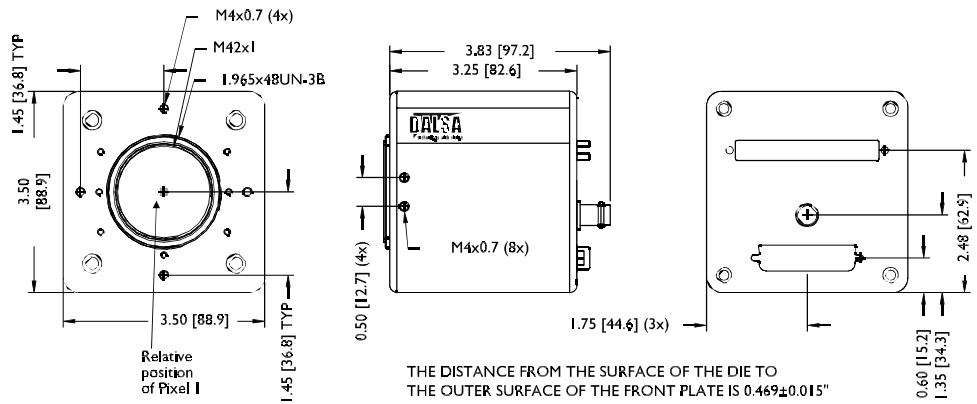
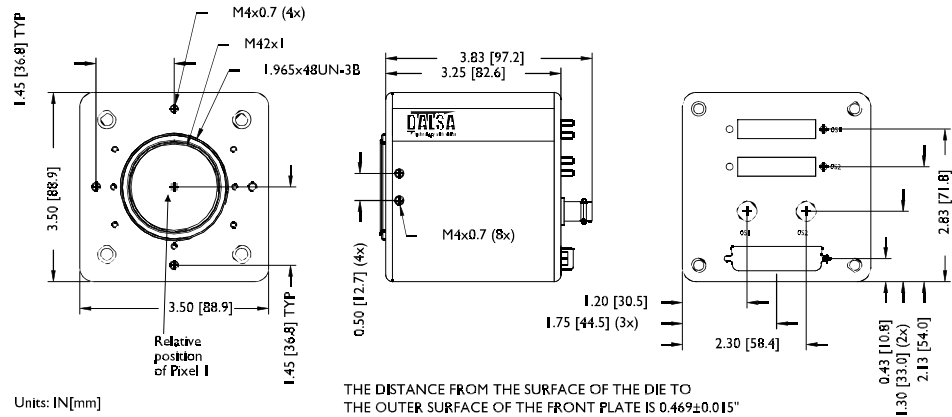

For More Information

For more detailed information on this and other products, including pinouts, timing, and signal descriptions, see the full product datasheet. Contact your local rep or visit our website at www.hailiangsz.com

DALSA Asia Pacific Sales
 ShenZhen Hailiang Precision Instrument Co.,Ltd
 TEL:86-755-83876045、83302909
www.hailiangsz.com

This information subject to change without notice.